

# MICROWAVE

## VIEWER MANUAL

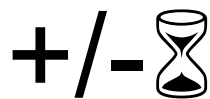
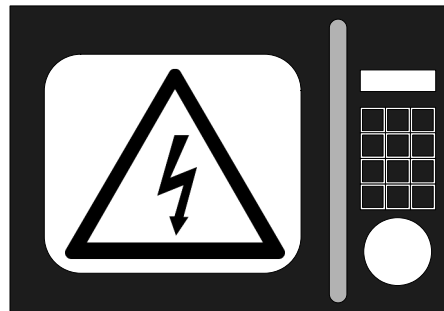

A film by Aaron G. Abrams

[www.MicrowaveTheFilm.com](http://www.MicrowaveTheFilm.com)

# MICROWAVE

## VIEWER MANUAL

### PLEASE READ THIS FILM GUIDE CAREFULLY

Congratulations on your viewing of the new film MICROWAVE.

Please contact our service department at [www.MicrowaveTheFilm.com](http://www.MicrowaveTheFilm.com) with any questions or comments.

### SAFETY PRECAUTIONS

The separation of the multiple universes is very important.



#### **WARNING**

Do NOT microwave anything **MAGNETIC** as this will cause a **DISRUPTION IN SPACE-TIME!**



#### **CAUTION**

Do NOT microwave anything **METAL** as this will cause **SPARKS** and possible **FLAMES**.

### IMPORTANT INFORMATION ABOUT MICROWAVE

- Please read this entire guide before attempting to view the film MICROWAVE.
- Some products such as whole eggs in the shell and sealed containers are able to explode and should not be heated in the microwave.
- As with all films, close supervision is necessary when used by children.

### SAVE THIS GUIDE

# GUIDE CONTENTS

---

FILM INFORMATION . . . . .	4
DIRECTOR'S STATEMENT . . . . .	5
CAST BIOGRAPHIES . . . . .	6
KEY PERSONNEL BIOGRAPHIES . . . . .	7
COMPLETE SCREEN CREDITS . . . . .	8
PRODUCTION STILLS . . . . .	10



## TECHNICAL SPECS

---



### Clock:

- MICROWAVE has a run time of 83 minutes including credits.

### Rating:

- MICROWAVE has an estimated MPAA rating of PG-13.

### Format:

- MICROWAVE is in color at a 4k resolution with a 2.39:1 aspect ratio.

## ELECTRICAL REQUIREMENTS

---



Please observe all governing codes and ordinances.

### Required:

- A 120 Volt, 60 Hz, AC only, 15- or 20- amp electrical supply with a fuse or circuit breaker.



Do NOT plug multiple devices including the microwave into a single power strip as this may cause a circuit overload and trip a breaker.

# FILM INFORMATION



## LOGLINE

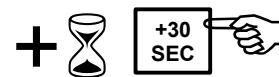

After a time-rift offers a glimpse exactly one minute into the future, four college-bound kids try to salvage their failing friendship as their perception of free will begins to fall apart.

## SYNOPSIS



Maggie, Daniel, Colin, and Hannah have been friends since elementary school. But now that they've graduated high school to embark upon the next chapter of their lives, they have their futures to worry about.

Hannah needs to ensure her microwave-themed web-series, "Let's Nuke It!", has enough content to fill the gap until next summer. Railroaded into a law career he's convinced himself he wants, Daniel can't wait to leave everyone behind and start with a clean slate. Colin has been rejected from every college he's applied to and has no clue what to do with himself. And Maggie has shunned college altogether, wishing for everything to stay the same.

On the night before they all part ways, a freak occurrence creates a time-slip allowing them to see one minute into the future, bringing about revelations of free will, destiny, and the potential for alternate universes...



# DIRECTOR'S STATEMENT



*“Will I stay friends with everyone after high school? What will I do with my life? Why don't colleges like me? What's the point of anything?”*

If you were at all like me in high school, those questions raced through your mind constantly as the threat of adulthood loomed ever closer.

Of course, the big joke of growing up is looking back and realizing that all the things which seemed world-ending at the time were actually not a big deal. It boils down to a strong fear of the unknown, the worry that things won't go well overpowering the equally likely possibility that they will.

This dichotomy is what the story of MICROWAVE explores, with its freshly-graduated characters being confronted by a literal view into a future they must discover how to control. Some see the time-slip as proof that nothing matters because there's no escaping fate. Others rail against it, seeing themselves as masters of their own destiny who must have control at all costs. While the story is filled with high-concept sci-fi shenanigans like characters spawning dimensional rifts which weave in and out of each other, the core of their existential fears are as real and universal as ever.

At least, they were real to me. All the people I had known my whole life were suddenly going to be gone, making new friends was hard, I didn't get into any of my dream colleges, and I had no clue how to pursue filmmaking as a legitimate career. That's a lot for a lad to take in at once.

It's easy to laugh off how high-strung “past me” was, but of course those feelings never went away; I simply got used to them. Writing this story has allowed me to go back and recall when it was all fresh, to be able to empathize with those fears while having a bit more life experience under my belt to navigate the characters through that change. That's not to say I have much more figured out, but who does?

I hope you will be able to find a little of yourself in the plights of Maggie, Colin, Hannah, and Daniel as they attempt to make peace with their place in not only this universe, but all universes.

- Aaron G. Abrams

# CAST BIOGRAPHIES

---



## **Violet Bryant**

(Maggie)

Violet Bryant trained in the Barrow Group Acting Approach at the Berkeley Repertory Theatre before landing her first film role in MICROWAVE. She is set to graduate from California State University, Northridge in 2023 with a degree in screenwriting.

## **Thang Derosé**

(Colin)

Thang Derosé is a Vietnamese actor born in Vietnam and moved to the quaint city of Sacramento, California. Originally going to school to become a lawyer, he could no longer quell the creative passion to pursue acting, performing in numerous short films and most recently the feature PUNK KIDS (2023). Besides acting, he is very involved with the fashion industry and helped co-create a few brands, ANTI Merch Co. and Tired and Emotional Co. among them. His end goal in life is to make an impact on the representation of the Asian-American creative community.

## **Nathan Payne**

(Daniel)

Nathan Payne is an actor with experience on both screen and stage. He is currently finishing his collegiate studies at the University of California, Berkeley and will be graduating with a degree in Theater and Performance Studies. MICROWAVE is Nathan's feature film debut and he recently made his debut on UC Berkeley TDPS' stage in LOVE AND INFORMATION last fall.

## **Felicia Stiles**

(Hannah)

Felicia Stiles is a Bay Area actress and content creator whose credits include BUMBLEBEE (2018) and FRESHMAN YEAR (2019). Her lifestyle YouTube channel, THE FEMININE FANCY, has over 230,000 subscribers and more than 130 videos.

# KEY PERSONNEL



## **Aaron G. Abrams**

Director / Writer

Aaron is a Bay Area filmmaker and assistant director who has written and directed over twenty short films in addition to promotional material for companies like Spring House Press and Alamo Drafthouse. His credits as an assistant director include the feature film LIVE OR DIE IN LA HONDA (2017) and the web-series PERSONAL SPACE (2018). He graduated summa cum laude from San Francisco State University in 2017, holding a Bachelor of Arts in Cinema.

## **Mister Masters**

Producer

Mister is a producer, writer, and director. Holding a degree in Cinema from San Francisco State University, he has produced several short films that have played in film festivals coast-to-coast. While he has worked for large-scale productions, like VENOM (2018), he prefers the tight-knit community and creativity provided by independent filmmaking.

## **Ryan Matthew Hagerty Moore**

Director of Photography

Ryan MH Moore is a Bay Area Native cinematographer with years of tech experience in both Camera and Lighting departments in the commercial and indie feature worlds. He has collaborated with Aaron Abrams before on the sci-fi short PAINCUBE.EXE (2017).

## **Camille Lund**

Co-Producer / Production Designer / Wardrobe

Camille is a freelance illustrator and animator. Having graduated from SFSU's Cinema program in 2018, she has worked in various departments on several short films, and her short film POTTY HUMOR won the Jury Award at the 2016 SFSU Campus Movie Fest.

## **Richard M. Petty**

Producer / Assistant Director / Sound Design

Richard has written and directed dozens of short films including his San Francisco State University senior thesis film, SHARKS (2018), which played at festivals in St. Louis and San Francisco. His short BIRD BULLIES (2022) won best comedy at the St. Louis Filmmaker's Showcase and was invited to screen at St. Louis International in competition. MICROWAVE is his first feature producing credit.

## **T.O.L.D.**

Composer

Los Angeles-based Daniel James Smith (aka T.O.L.D.) is a fearlessly creative writer/producer from England. Daniel got his start in the UK underground as a teenager pioneering the auto-tuned emo sound. He quickly got picked up by Red One and Island Records to work on chart hits. In 2014, he moved to LA to work on his meditative debut album which received critical acclaim by The New York Times, Noisey & Apple Music.

# COMPLETE SCREEN CREDITS



## CAST

Hannah Vargas FELICIA STILES  
Maggie Keller VIOLET BRYANT  
Daniel Levin NATHAN PAYNE  
Colin Yang THANG DEROSE

Mrs. Henderson JULIE DIMAS  
Mrs. Keller BETH BARNES  
Mr. Levin COLIN HUSSEY  
Brent ALEX SANDRU

## CREW

Writer AARON G. ABRAMS  
Director AARON G. ABRAMS  
Producers AARON G. ABRAMS  
MISTER MASTERS  
RICHARD M. PETTY  
Co-Producers CAMILLE LUND  
RYAN MATTHEW  
HAGERTY MOORE  
Associate Producer DENNIS METAXAS  
Executive Producers AARON G. ABRAMS  
ARNIE ABRAMS  
SERENA ABRAMS  
Director of Photography RYAN MATTHEW  
HAGERTY MOORE  
Production Designer CAMILLE LUND  
Costume Designer CAMILLE LUND  
Editor AARON G. ABRAMS  
Unit Production Manager MISTER MASTERS  
First Assistant Director RICHARD M. PETTY  
2nd Assistant Directors MARIAN MCCOLM  
MISTER MASTERS  
Additional 2nd AD EDGAR VEGA

"A" Camera Operator RYAN MATTHEW  
HAGERTY MOORE  
"B" Camera Operator MARTIN BUSTAMANTE  
1st Assistant Camera MARTIN BUSTAMANTE  
MICHAEL BELTRÁN  
IDO BARTANA  
2nd Assistant Camera MICHAEL BELTRÁN  
JESSICA LE  
Pick-up Photographer ALEX AJAYI  
Script Supervisor NICK SMITH  
Production Sound Mixer NATHAN LUDICKE  
Boom Operators MADISON GUNTER  
PAUL KORTJOHN  
COLIN MCDONALD  
HECTOR SANCHEZ  
JOZIE ZAMJAHN  
Composer T.O.L.D.  
Re-recording Mixer DANIEL JAMES SMITH  
Dialogue Editor AARON G. ABRAMS  
Foley Artist RICHARD M. PETTY  
Sound Design RICHARD M. PETTY



## CREW CONTINUED

<p>Gaffer AARON WARE</p> <p>Best Boy/Girl Grip MARKUS FIELDS</p> <p style="padding-left: 40px;">JESSICA SCHLEGEL</p> <p style="padding-left: 40px;">SASHA SHVACHKO</p> <p style="padding-left: 40px;">PATRICIO TREJO LERDO</p> <p style="padding-left: 40px;">EMILY WOHLFORD</p> <p>Best Boy/Girl Electric DOMINIC CIRIGLIANO</p> <p style="padding-left: 40px;">DIANA RODRIGUEZ</p> <p>Key Grips ALEX AJAYI</p> <p style="padding-left: 40px;">NICK VAUGHN</p> <p>Swing Grips Q. IRENE PENG</p> <p style="padding-left: 40px;">CALUM RUXTON</p> <p>Location Manager ARNIE ABRAMS</p> <p>Property Master CAMILLE LUND</p> <p>Set Dresser CAMILLE LUND</p> <p>Additional Set Dresser JUSTIN ARAGON</p> <p>Carpenters ARNIE ABRAMS</p> <p style="padding-left: 40px;">EDDIE KERBEL</p> <p style="padding-left: 40px;">PAUL KORTJOHN</p> <p style="padding-left: 40px;">RICHARD M. PETTY</p> <p>Makeup Artist SAMMY-LEU</p> <p>Hair Stylists SAM GAGLIARDI</p> <p style="padding-left: 40px;">SAMMY-LEU</p>	<p>Casting AARON G. ABRAMS</p> <p style="padding-left: 40px;">CAMILLE LUND</p> <p>Stills Photographer DELEVAN TAM</p> <p>Legal Services GEORGE RUSH</p> <p>Key Set Production PAUL KORTJOHN</p> <p style="padding-left: 40px;">Assistant</p> <p>Production Assistants MILES BARTLE</p> <p style="padding-left: 40px;">STEVEN CLOYES</p> <p style="padding-left: 40px;">KENNY DZIB</p> <p style="padding-left: 40px;">KIYOSHI KUMAGAI</p> <p style="padding-left: 40px;">JASON LAMB</p> <p style="padding-left: 40px;">ROBERT NEGOESCO</p> <p style="padding-left: 40px;">NICK NGUYEN</p> <p style="padding-left: 40px;">AARON PHAM</p> <p style="padding-left: 40px;">ADAM ROSENBERG</p> <p style="padding-left: 40px;">HECTOR SANCHEZ</p> <p style="padding-left: 40px;">JUSTIN TEIXERIA</p> <p style="padding-left: 40px;">EMILY WILBURN</p> <p style="padding-left: 40px;">ELENA WYLLIE</p> <p>Craft Service SERENA ABRAMS</p> <p>Colorist MILES BARTLE</p> <p>Visual Effects Artists AARON G. ABRAMS</p> <p style="padding-left: 40px;">CAMILLE LUND</p>
--	--

DO NOT ATTEMPT TO DISASSEMBLE MICROWAVE YOURSELF. CONTACT OUR SERVICE DEPARTMENT AT [WWW.MICROWAVETHEFILM.COM](http://WWW.MICROWAVETHEFILM.COM)

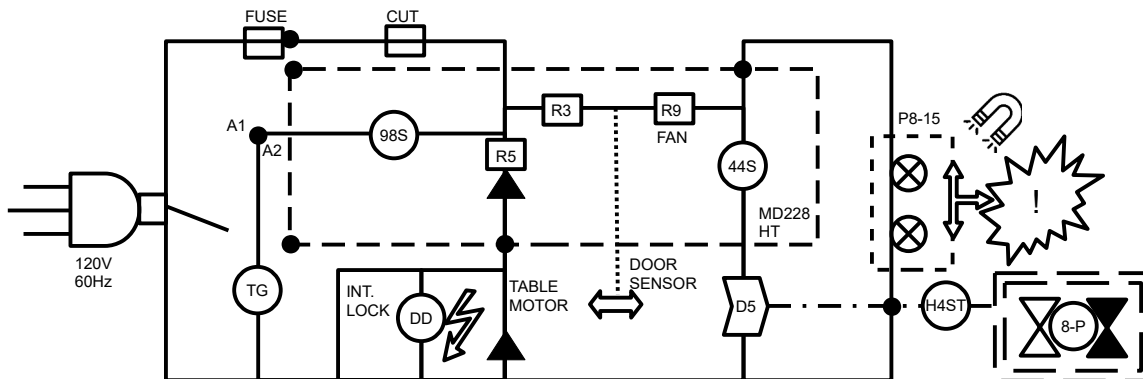

# PRODUCTION STILLS

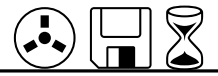

# PRODUCTION STILLS

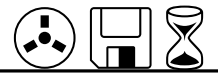



English  
Question?  
Microwave  
[www.MicrowaveTheFilm.com](http://www.MicrowaveTheFilm.com)

Español  
¿Pregunta?  
Microondas  
[www.MicrowaveTheFilm.com](http://www.MicrowaveTheFilm.com)

Français  
Question?  
Four micro onde  
[www.MicrowaveTheFilm.com](http://www.MicrowaveTheFilm.com)

Deutsch  
Frage?  
Mikrowelle  
[www.MicrowaveTheFilm.com](http://www.MicrowaveTheFilm.com)

Italiano  
Domanda?  
Microonde  
[www.MicrowaveTheFilm.com](http://www.MicrowaveTheFilm.com)

Português  
Pergunta?  
Microondas  
[www.MicrowaveTheFilm.com](http://www.MicrowaveTheFilm.com)

日本  
質問?  
電子レンジ  
[www.MicrowaveTheFilm.com](http://www.MicrowaveTheFilm.com)

中国人  
问题?  
微波  
[www.MicrowaveTheFilm.com](http://www.MicrowaveTheFilm.com)

한국어  
의문?  
마이크로파  
[www.MicrowaveTheFilm.com](http://www.MicrowaveTheFilm.com)

русский  
Вопрос?  
Микроволновка  
[www.MicrowaveTheFilm.com](http://www.MicrowaveTheFilm.com)

український  
Питання?  
мікрохвильова піч  
[www.MicrowaveTheFilm.com](http://www.MicrowaveTheFilm.com)

עברית  
שאלה?  
מיקרוגל  
[www.MicrowaveTheFilm.com](http://www.MicrowaveTheFilm.com)

Guide Designed by  
Richard M. Petty  
2022

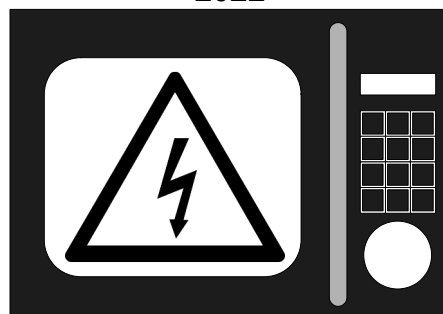

[www.MicrowaveTheFilm.com](http://www.MicrowaveTheFilm.com)